



A Touchstone Energy® Cooperative 
The power of human connections®

New Construction Handbook

New Construction Services & Engineering

Garkane Energy Cooperative

120 W. 300 S

Loa, UT 84747

800-747-5403

www.garkaneenergy.com

GENERAL INFORMATION

***All equipment, materials, boxes, connectors, conduit, conductors, etc... must be UL listed for the intended application.**

Application for Service

All applications for service from Garkane Energy Cooperative (Garkane) shall be in accordance with its Extension Policy and Electric Service Regulations. In all circumstances the applicant shall be the fee owner of the property to be serviced by the extension.

By Garkane policy, all electric facilities on the member side of the Garkane meter (Point of Delivery) is constructed by, owned by and the responsibility of the member. Installation of all facilities on the Garkane side of the meter, including the transformer, are designed and installed by Garkane and remains the property of Garkane unless otherwise noted. It is the responsibility of Garkane to operate and maintain all assets on its side of the meter.

The first step in starting new construction with Garkane is to sign and complete a “New Construction/Upgrade Service Application”, provide a simple service site map with dimensions and location of service, provide load calculations if required and submit a nonrefundable engineering deposit of \$390. This deposit will go towards expenses such as those incurred as part of the design process and will be applied towards the final cost of the job. The completed application for new service will place the applicant’s/member’s request for service into the New Construction Schedule queue and will also be used to establish a billing account for the new service. Each additional estimate needed will require a \$390 deposit.

Preconstruction Tasks

Depending on the service location, size, and length, additional work tasks may need to be completed prior to scheduling installation of the service. These tasks include completing any special permitting requirements, obtaining right-of way and easements and/or the procurement of metering, special equipment and unusually large amounts of construction materials. If these preconstruction tasks are not applicable to a project they are omitted from the process and construction may be scheduled once all the fees are paid. In the event some or all the preconstruction tasks are applicable to a project, work on the tasks will begin immediately after payment of project fees.

Design and Construction Cost

Garkane will handle requests for new construction services in the order the requests are received but will also consider applicant's/member's circumstances and needs when establishing its design and construction schedules. If requested, once the job progresses to the top of the schedule, a System Designer will contact the applicant/member for an on-site appointment. During this appointment the System Designer will go over proposed line routes, equipment locations, permits, right-of-way easements and estimated costs.

When complete project information is obtained and required documents are completed, the System Designer will design the job and determine the final cost estimate approximately 30 business days from receipt of of Engineering deposit. All costs shall be determined by Garkane's current unit construction costs and will include all costs necessary for the extension of facilities including design expenses, right-of-way investigation, and any necessary licenses and permits. Any changes to the design or additional trips to the site may result in additional expense to the applicant/member.

Kl'c'r tqlgev'tgs wktgu'o qtg'gpi kpggtkpi 'vko g'vj cp'vj g'ucpf ctf "&5; 2'gpi kpggtkpi 'hgg.'c's wkeni' guvko cvg'y kn'dg'r tqxkf gf 0'Vq'tgegkxg'c'dkpf kpi 's wqvg.'32' "qh'vj g'dwf i guct { "guvko cvg'o wuv'dg" r ckf "vq'i gv'c'hwm'gpi kpggtgf "equv'guvko cvg'0'Vj ku'pqp/tghw'pf cdrg'kpxguvo gpv'y kn'hcekrkcvg'"vj g" f gckrgf 'r rcpplkpi "cpf "cuuguo gpv'pgeguuct { "vq'hkpcrk g'vj g'r tqlgev'cpf 'r tqxkf g'c"eqo r tgj gpukxg" equv'dtgcnf qy p0Gzco r rgu'kpenwf g<J qvgnu."uudf kxkukqpu."i cu'ucv'kqpu."GX"ej cti kpi "ucv'kqpu."TX" r ctmu and other large projects.

Due to the current economic situation, Garkane will be adhering to the following guidelines:

Cost estimates are valid for 30-days, beyond 30-days, Garkane will update estimates to reflect our current material costs and labor rates at the time of payment. If the estimate has not been paid after 6-months from the date of original estimate, Garkane reserves the right to cancel/close out the job and any unused funds will be refunded.

If a project has not been progressing after 6-months from time of receipt of payment, Garkane reserves the right to cancel/close out the job and any unused funds will be refunded.

If a project has not been completed for any reason within 6-months after receipt of payment, Garkane may require additional payment to cover all cost increases in project materials and labor.

If a project's scope of work has changed in any way by the member after Garkane staff has started work on the project, Garkane will require payment for any additional materials and labor needed to complete the project.

If for any reason the project is cancelled after materials have ordered, there may be a 5% procurement fee, which will be deducted from the project refund.

Permitting

Projects crossing public lands, or endangered species habitat generally require that Garkane obtain permits from various governmental agencies prior to starting construction. In these cases, after receiving payment Garkane's System Designer will work with the appropriate authorities and our environmental consultant to complete the permitting process. The cost of obtaining the permits will be the responsibility of the applicant/member. Once the appropriate permits are obtained responsibility for the project will pass from Garkane's System Designer to our Area Manager who will schedule construction of the project with the applicant/member.

Right-of-Way Easements and Access

If an easement is required for the construction of new power lines, it will need to be obtained prior to installation of the requested service. In the event Garkane must cross property other than that of the member requesting the service, the requesting member will be asked to obtain all easements needed. A platted and dedicated front lot easement will be provided for utilities in all subdivisions. If the power line is along a county road, Garkane will have an easement of 15 feet. All other distribution voltage easements will be 25 feet (12.5 feet from the center of the installed utility line). Once the appropriate easements or right-of-ways are obtained responsibility for the project will pass from Garkane's System Designer to the Area Operations Manager who will schedule construction of the project with the applicant/member.

Materials Procurement

Construction of 3 phase services or services larger than 200 amp may require that Garkane order project specific equipment. Additionally, projects requiring a large amount of construction materials will require that Garkane procure additional project materials. In these circumstances Garkane will order the additional project materials upon receipt of payment. A materials delivery time estimate will be provided. Once all materials are delivered responsibility for the project will pass from Garkane's System Designer to our Area Operations Manager who will schedule construction of the project with the applicant/member.

Scheduling and Site Readiness

Once the job has been designed, paid for and the preconstruction tasks are completed, Garkane's System Designer will pass responsibility for the job to the Area Operations Manager. At that time the Area Operations Manager will assume responsibility for the project and will oversee scheduling the job with the member/applicant. **Garkane assumes no liability for unforeseen factors that delay the project completion date.**

Garkane will own, design, construct, operate, and maintain all facilities, including meters on Garkane's side of the point of attachment for all classes of service.

*Please note that temporary power is allowed for **no more than 12 months** while construction is being completed. Garkane reserves the right to disconnect services that have not transitioned from temporary to permanent after the 12-month period has expired.*

Before New Service Can Be Energized

The **Inspector having jurisdiction** must inspect and approve the member's electrical equipment & installation before it can be connected by Garkane.

Kane County: 435-644-4985

Garfield County: 435-676-1111

Wayne County: 435-979-1279

Sevier County: 435-893-0420

Piute County: 435-577-2949

Mohave County: 928-715-0237

Twin Cities: 435-703-0050

Extra Trip Fee

Garkane reserves the right to assess a flat charge to any member causing a construction delay for Garkane construction crews. A construction delay is any trip to the job site made by a construction crew where the scheduled work could not be completed by the construction crew because conditions at the site were different than what was represented by the member when the appointment was scheduled by the member. **A minimum charge of \$200 per occurrence will be assessed.**

Call Blue Stakes Before You DIG - 811

For all underground utility line locates contact the Blue Stakes by dialing **811** at least two business days prior to starting excavation. Garkane or Garkane Sub-contractors will not be responsible for damage to underground facilities that are member owned and have not been accurately located; including, but not limited to septic tank(s), sewer line(s), irrigation pipe(s), sprinkler(s), leach field(s) or any other facilities.

The member-furnished trench must be provided in accordance with Garkane's trench specifications. In no circumstance will Garkane be responsible for costs associated with trenches including dirt or rock work.

Will Serve Letter

Email requests for a Will Serve letters to FSR@garkane.com and include the service address, parcel number, site map, service size and description of what will be developed. A \$50 fee will be charged for all residential Will Serve letters and \$100 fee for all commercial Will Serve letters.

Plant Investment Fees

The Plant Investment Fee shall be based upon the service main bus amperage and nominal service voltage. Where there is more than one service entrance, main breakers and/or fuse sets, the investment fee shall be based upon the sum of such devices.

Main Disconnect Capacity		200 Amps	400 Amps	600 Amps	800 Amps
Single Phase	240 Volts	\$500	\$1,000	\$1,500	\$2,000
	480 Volts	\$700	\$1,400	\$2,100	\$2,800
Three Phase	240 Volts	\$1,500	\$3,000	\$4,500	\$6,000
	480 Volts	\$2,100	\$4,200	\$6,300	\$8,400

A Plant Investment Fee of \$2.50/amp will be added to the cost of any new or upgraded residential or commercial service to fund general improvements to Garkane's System for all services 240 Volts or less.

A Plant Investment Fee of \$3.50/amp will be added to the cost of any new or upgraded residential or commercial service to fund general improvements to Garkane's System for all services greater than 240 Volts

All facilities requiring a three phase service will pay the appropriate Plant Investment fee amp charge for each phase installed... Example: (600 amps x 3 phases) = 1800 amps x \$2.50 or \$3.50

Service entrances which are upgraded and result in increased capacity shall be assessed a plant investment fee equal to the difference between the original service entrance size and the upgraded service entrance size. Service entrances, which are upgraded for safety reasons or system improvements without increase in service capacity, may have the plant investment fee waived.

Upgrading of existing service will require payment of the applicable Plant Investment fees based on the difference in cost between the calculation of the exiting installation size and the capacity versus the cost of the new installation in size and capacity.

Area specific impact fees to recover cost on upgrade investments and infrastructure installation

Impact Fee Zion Ponderosa Area - \$2,400

Zion View Area - \$7,500

Special Considerations for Motor Loads

- Motors over 10 hp must be served with three-phase power, unless approved by Garkane's Engineer.
- All motors over 5 hp shall have starting current limited to no more than 3 ½ times full load rating for no more than 15 seconds.
- Motor loads with variable frequency drives may require: upgrading transformer size (pole class may have to increase), decreasing transformer impedance, increasing service wire size, decreasing service wire length and harmonic filters to reduce Total Harmonic Current Distortion at the member's meter (per IEEE Standards 519). These changes will be at the member's expense.
- Garkane strongly recommends electrical protection on three-phase motors. This protection should include: loss-of-phase, reverse phasing and low-voltage protection (including low-voltage protection for single-phase motors). Garkane will not assume responsibility for damages related to a member's lack of effective protection.
- Motor loads should be compensated for their reactive power usage by installation of shunt capacitors. Power Factor shall be between 95% lagging and 100%. Leading Power Factor is not permitted.
- New installed motors or any other load shall cause less than 3% voltage flicker (per IEEE Standard 141) at the member's meter.

Garkane's Vegetation Management Program

At Garkane Energy Cooperative, we strive to balance maintaining beautiful surroundings and ensuring a reliable power supply by keeping our power lines clear of obstructions in our right-of-way (ROW).

While we recognize and appreciate the beauty of trees, there are three main benefits to tree trimming in ROW areas. However, before touching on the main reasons, let me explain what a ROW is and how it can impact you. A ROW is the corridor we use to construct, maintain, replace or repair underground and overhead power lines. ROW enables the co-op to provide clearance from trees and other obstructions that could hinder power line installation, maintenance or operation.

The overall goal of our vegetation management program within a ROW is to provide reliable power to our members while maintaining the beauty of our community. Proactive vegetation management benefits co-op members in three tangible ways.

SAFETY

First and foremost, we care about our members and put their safety and that of our line workers above all else. Overgrown vegetation and trees in our ROW presents a risk to power line safety. For example, if trees are touching power lines in our members' yards, they can pose grave danger to families. If children can access those trees, they can potentially climb into a danger zone. Electricity can arc, or jump, from a power line to a nearby conductor like a tree. A proactive approach to remove limbs or entire trees diminishes the chances of fallen branches or trees during severe weather events that make it more complicated and dangerous for line workers to restore power. Generally speaking, healthy trees don't fall on power lines, and clear lines don't cause problems. Proactive trimming and pruning keeps lines clear which in turn, promotes greater reliability.

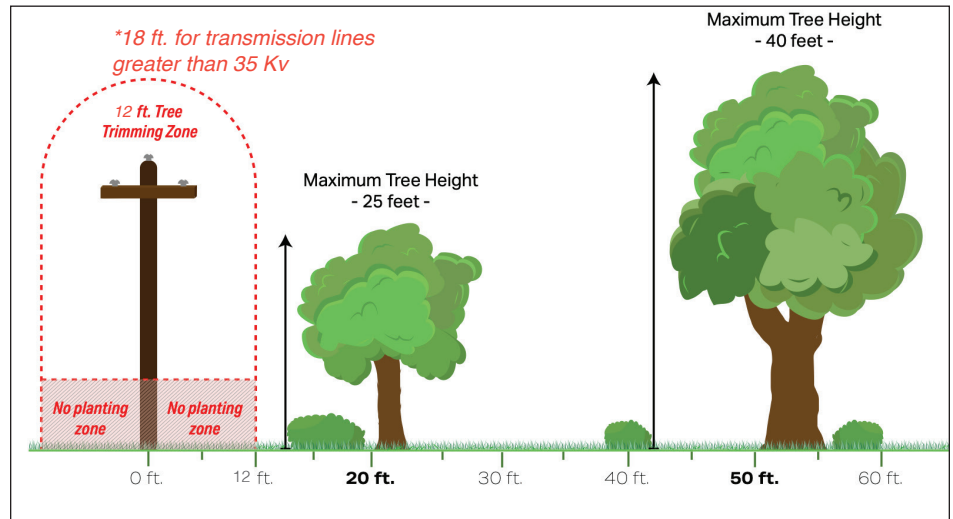

Tree Planting Guide

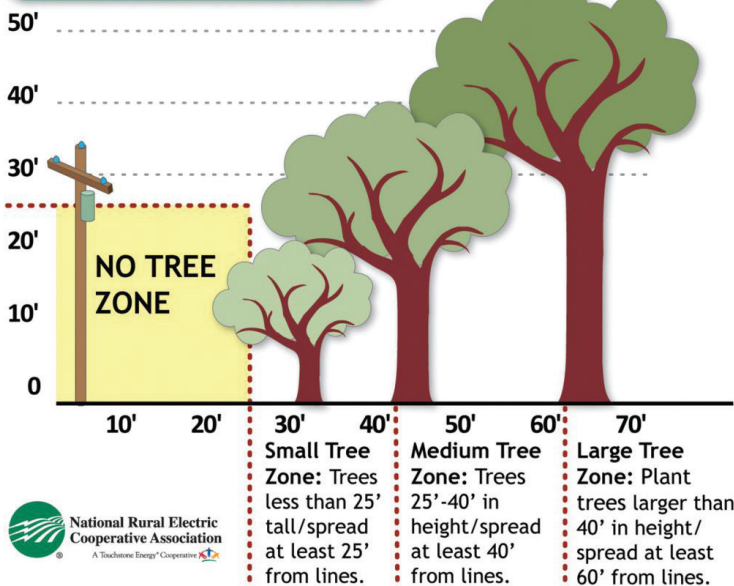

Recommended Trees to plant in Southern Utah

Pekin Lilac, Hedge Maple, Golden Rain Tree, Japanese Tree Lilac, Amur Cork Tree, Chinese Date, Amur Maple, Mayday Tree, American Hornbeam, Serviceberry, Thornless Cockspur Hawthorn, Winterking Hawthorn Shubert, Chokecherry, Washington Hawthorn

TREE TYPES
The taller a tree will become, the further it needs to be from overhead lines.

SMALL <20 FT	MEDIUM 25-50 FT	LARGE 40+ FT
If planting within 15 feet of power lines	Plant minimum 20 feet from overhead lines	Plant 50+ feet away from overhead lines
Flowering Crabapple Flowering Dogwood Sweetbay Magnolia Serviceberry Redbud Walter-Ash Common Hawthorn	Flowering Crabapple Flowering Dogwood Sweetbay Magnolia Serviceberry Redbud Walter-Ash American Arborvitae Junipers Japanese Yew False Cypress Common Hawthorn Evergreens	Norway Maple Linden or Basswood London Plane Ginkgo Sweetgum Oak Sugar Maple Evergreens White Pine Austrian Pine White Firs Blue Spruce
TREES NOT SUITABLE NEAR POWER LINES Catalpa • Carolina Poplar • Silver Maple • Boxelder • Willow • Siberian Elm • Black Locust • Cottonwood Tree of Heaven • Mulberry • Elm species		

ELECTRICAL SAFETY CODE CLEARANCES

The National Electrical Safety Code is used for the design, construction, maintenance, and operation of Garkane's electric transmission and distribution system. Garkane reserves the right to terminate service without prior notice when a hazardous condition exists. **A specified clearance will be maintained over state highways, all streets, county roads, driveways and residential properties. The National Electric Safety Code or the authority having jurisdiction regulates the clearance heights.**

To comply with National Electrical Safety Code requirements, easement and right-of-way finished grades cannot be changed more than six inches by excavation or filling without prior approval of all utility companies involved. Buildings or other structures shall not be constructed within utility easements. **If the member does build within a utility easement, the line will be moved at the member's expense.** Landscaping within an easement is permissible but shall not violate Garkane's Tree Trimming Policy (see Tree Trimming policy).

Clearances of Secondary Wires, Conductors and Cables

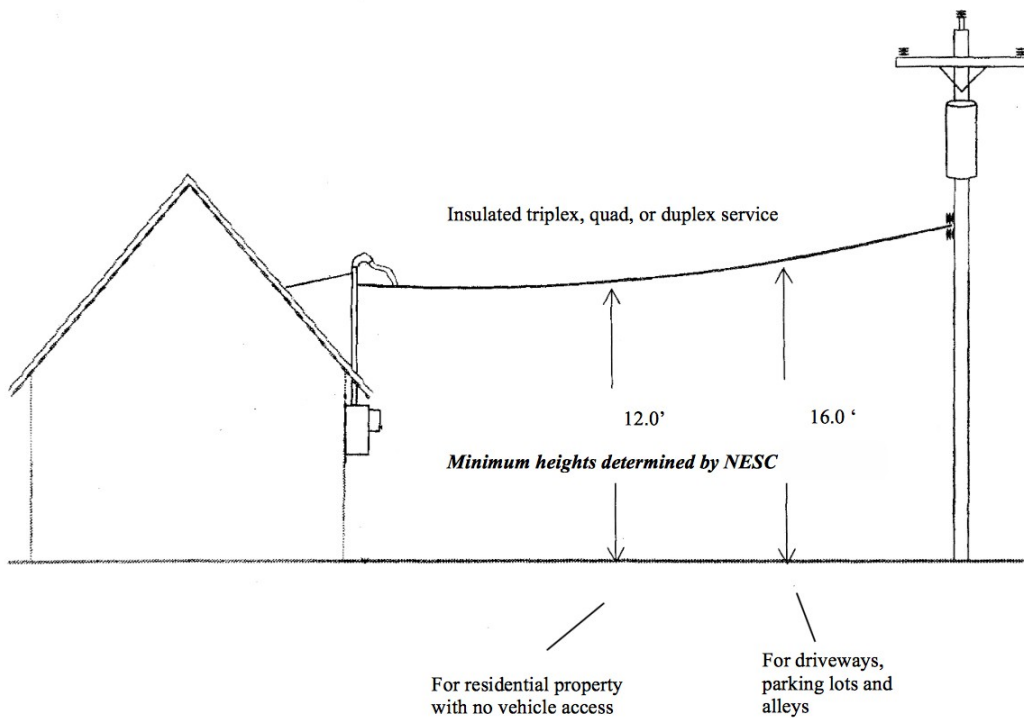

***All equipment, materials, boxes, connectors, conduit, conductors, etc... must be UL listed for the intended application.**

TREE TRIMMING POLICY

The following guidelines shall be used when obtaining right-of-way for the purpose of building and maintaining utility lines.

- Trees, shrubs or bushes shall not be planted directly above underground or below overhead utility lines. Before digging to plant anything, it is the member's responsibility to call 811 to locate the underground utility lines.
- All trees, shrubs or bushes must remain at least five feet on either side of locates and flags designating underground utility lines.
- The member assumes responsibility for all trees, shrubs or bushes that are planted in the utility easements. In the event that Garkane has to excavate any utilities in the easement or maintain any equipment, Garkane will not replace or be responsible for any trees, shrubs or bushes that need to be removed.
- All 120/240/480-volt triplex/quadruplex services must maintain a minimum clearance of a one-foot radius from all trees or branches.
- All open secondary wire will need a minimum clearance radius of 5 feet from all trees or branches.
- All primary wire will require a minimum clearance radius of 10 feet from all trees or branches.
- A Garkane field representative will ensure that all tree trimming is complete prior to constructing a job. No lines will be energized until clearances are met.
- The member always has the option of underground construction (at the member's expense) if the necessary overhead right-of-way clearances cannot be made.
- Garkane is presently utilizing the "Shigo Method" for all tree trimming and maintenance applications. This method is endorsed and promoted by the National Arborist Association.

On all maintenance tree trimming where the member does not allow the Shigo Method, the member has the option to have the tree topped or shaped. If the member elects to have the tree topped or shaped, it will be done at the member's expense. The member will be responsible for all hours spent by the contractor. The member will be required to reimburse Garkane for payment made to the contractor. This will be done every time a tree is trimmed by any option other than the Shigo Method. The ten-foot rule will apply to all primary conductors upon completion of topping or shaping.

Due to insurance and OSHA regulations, only tree trimming contractors hired by Garkane are allowed to work within ten feet of primary conductors.

With these guidelines in place, and by utilizing the Shigo Method for tree trimming, Garkane will rotate on a three-year cycle for tree trimming and tree removal. This cycle will save Garkane and the member money.

SPECIFICATIONS FOR METER INSTALLATIONS

General

Garkane will make permanent connections between the member's electric service wiring and Garkane's system. Unauthorized connections are not permitted. Garkane will furnish, maintain and retain ownership of all meters and instrument transformers. Terminations will only be allowed on the exterior of the facility being metered. No Garkane termination will be inside or enter the member's facility.

Removal, relocation or performing of any work on an electric meter without Garkane's permission is prohibited. Tampering with Garkane's metering equipment, making an unmetered connection, or making an unauthorized reconnection to Garkane's system is prohibited and the member will be subject to disconnection and/or fines.

Garkane is not responsible for member owned facilities, such as, but not limited to meter bases/loops.

Meter Locations

- Meters will be located: 1) at the lot-line, 2) on the front of the house, 3) within the front third of the front corner of the house, or 4) the street side and Always Accessible and Safe.
- If a member-owned meter base/loop (contingent upon Garkane approval) is located on a Garkane secondary pole, it will be at the member's expense to relocate their facilities in the event the pole is damaged or needs to be replaced.
- Meters will not be located in any area considered hazardous, flammable or where reading, testing or servicing of the meter may become impractical, (i.e. behind fences, enclosures, or shrubs, under decks, around dangerous animals, or inside structures). If meters are not accessible, they will be moved at the member's expense.
- Meters will be located no less than 4' and no more than 6' above final grade.
- No steps or stairways will be permitted or required as access to meters.
- Meters will be located at least 4' away from gas meters and vents.
- Meters are owned, installed, and maintained by Garkane.
- Multiple meter sockets must each be clearly marked with permanent scribed tags (at the member's expense) to identify correct addresses. Correct meter labels and appropriate addresses shall be verified by member's electrician before permanent meters will be installed.
- Garkane will not attach its supply wires to more than one meter on a single structure, unless the meters are grouped together in such a manner that all are energized through the same transformer.
- All service locations that receive a significant amount of snow will be installed using underground
- methods. Services damaged due to snow will be required to be reinstalled using underground methods at owners expense.
- Meter Bases located inside livestock areas will require a cattle fence. Members will be responsible for any damages to GKE equipment due to livestock.

Self-Contained Metering Installations

For single-phase self-contained metering installations, the member provides and maintains the meter socket, and Garkane provides (at the member's expense) and maintains the meter.

For single-phase services requiring power at 120/240 volts having a service rating of 200 amps or less, a properly sized self-contained UL approved 4 jaw meter socket will be installed. A 240/480 volt single-phase service requires a 600 volt meter socket properly sized, UL Listed with **manual lever bypass switch** and

accessible 600 volt main disconnect and 5 jaw socket with stem in 6 o'clock position. A 120/208 single-phase self-contained work meter must be provided with a 5-jaw socket with the 5 terminal in the 6 o'clock position.

The member provides and maintains all self-contained meter sockets including multiple meter stacks. Three-phase self-contained meter sockets with a **manual lever bypass switch** will be UL-Listed.

Any **commercial** account that requires a self-contained meter, including network meters, must have a **manual lever bypass switch**. Self-contained meter sockets with a manual lever bypass switch will be UL-Listed.

For single-phase services with a capacity greater than 200 amps and including, but not exceeding 400 amps, a 400 amp (320 amp continuous rating) meter socket will be installed with a minimum service wire size of 350 MCM, a **manual lever bypass switch**, locking jaws and a disconnect or disconnects that will de-energize the entire panel. *Disconnects must be accessible to Garkane personnel.* The continuous load for these services shall not exceed 320 amps. Meter bases with a continuous rating of 400 amps or sockets for bolt-in meters are not acceptable.

Any service greater than 800 amps requires the submittal of engineering construction drawings to Garkane's Metering department for review and approval at least 30 days prior to purchase and installation.

In the event of a failure, the member or a licensed electrician will replace the meter socket and wire within the service mast. Inspection will be required by the appropriate Electrical Inspector if wire within service mast has to be replaced. Garkane will not be responsible for any code violations found outside the scope of Garkane work.

Instrument Transformer (CT) Metering Installations

- Garkane provides and maintains (at the member's expense,) all single-phase and three-phase CT-metered meters and meter sockets except for multiple meter stacks.
- CT's will be located in a CT cabinet furnished by the member, unless otherwise approved by the Garkane Engineering Department. For CT cabinets 2,000 amps or less, the customer will provide a UL-Listed bar-mounted CT cabinet. For services greater than 800 amps (where member chooses to use switchgear cabinet) the CT cabinet specification will be approved by the Garkane Engineering Department.
- The point of demarcation will be the member furnished bar-mounted CT cabinet or weatherhead. The cabinet must meet minimum NEC size requirements.
- For terminations in the bar-mounted CT cabinet, the member will provide the approved connectors and terminate all wires within the box.
- Members will not have access to Garkane's transformer, only Garkane will have this access. Garkane will make all connections in the transformer.
- Terminations will only be allowed on the exterior of the facility being metered. No Garkane termination will enter the member's facility.
- CT meter sockets will not be mounted on switchgear doors.

CT's will be installed in a CT cabinet mounted on the member's facility and furnished by the member. The minimum size CT cabinet will be 32" by 36" by 10". No CT's will be mounted on poles or external to cabinets. The meter will be mounted within 10 feet of the CT cabinet at member's facility. Customer may supply and install all wire and conduit to the CT cabinet. Garkane's System Designer will determine the number and size of wire and conduit to be installed. The service entrance knockouts in the CT cabinet are the responsibility of the member and location of the knockouts will be specified by Garkane.

The member will provide all connectors and terminate all service wires inside the CT cabinet.

A Garkane Operations or Engineering Manager/Supervisor must approve any exceptions to the above in writing.

Electricians needing Short Circuit Currents for Commercial Installations (per NEC 110-24) to pass State Electric inspections should plan on at least five business days to obtain this information from a System Designer at Garkane.

Inactive Service Inspection: After 1 year of a service being disconnected or de-energized, the property owner must obtain an electrical inspection by the building inspector to verify a safe system still exists. Upon Garkane-approved evidence of inspection, Garkane will connect and energize the system.

WORKING CLEARANCES FROM ELECTRIC METER

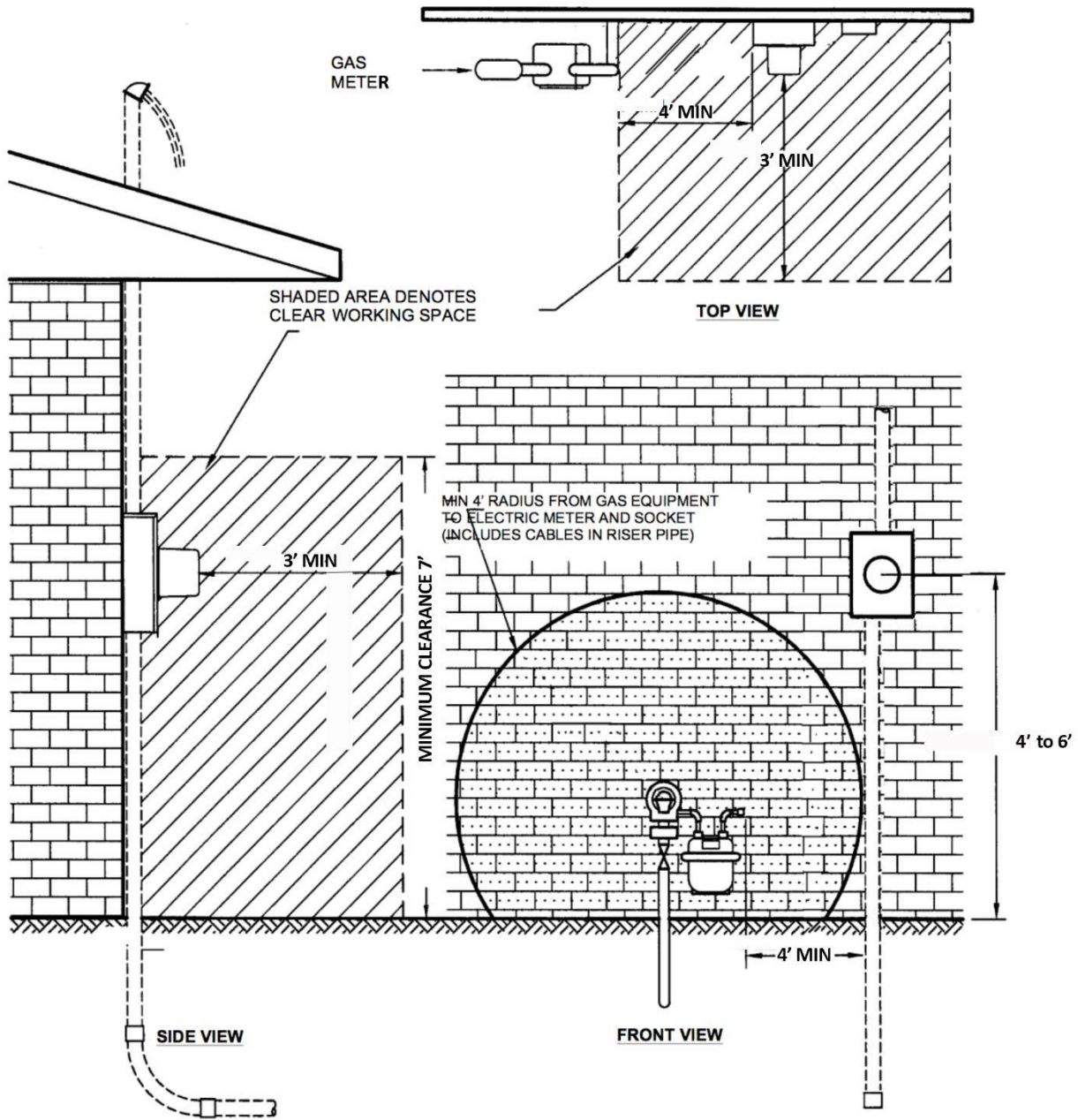

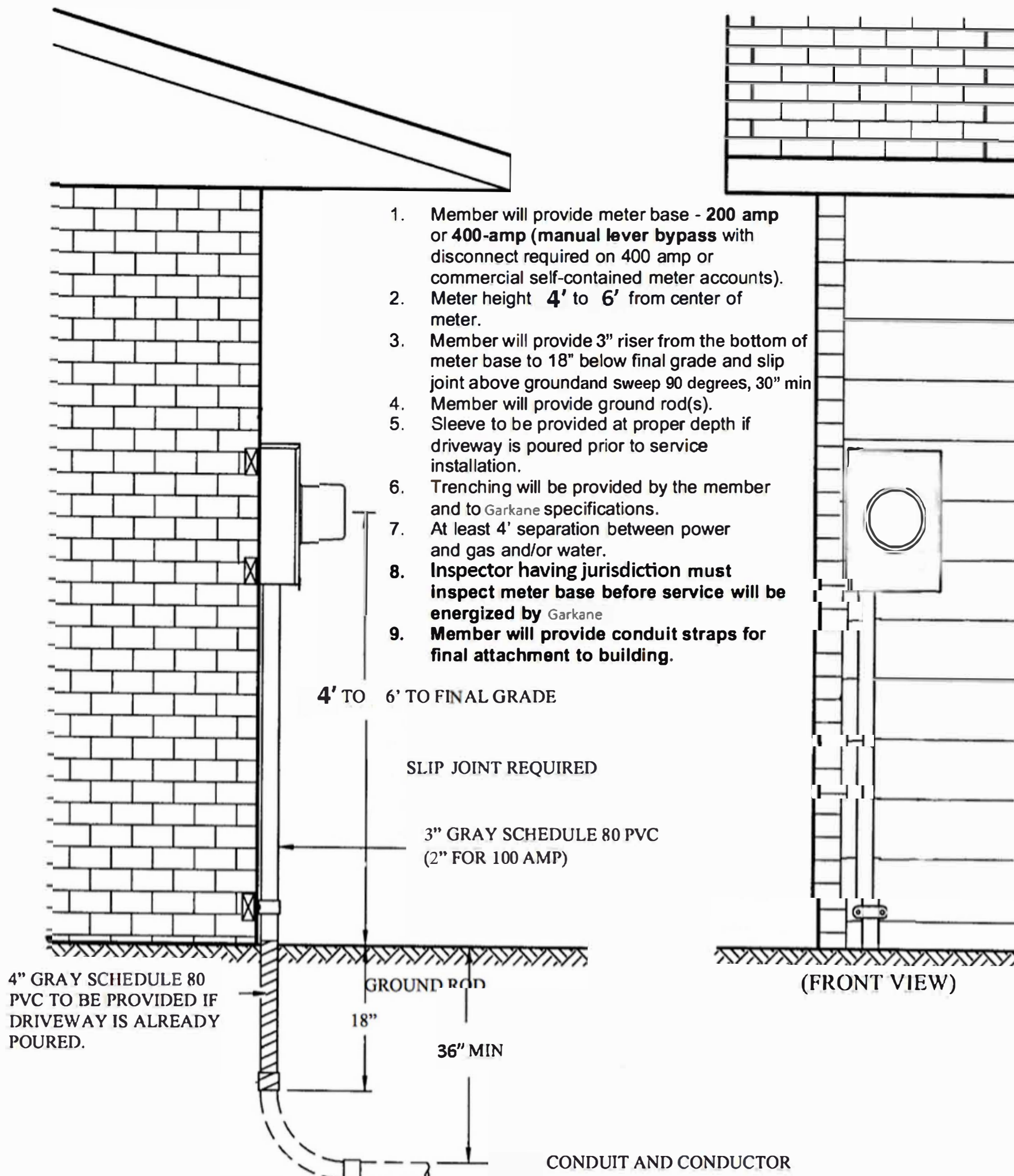

UNDERGROUND SERVICE INSTALLATIONS

PERMANENT METER PEDESTAL

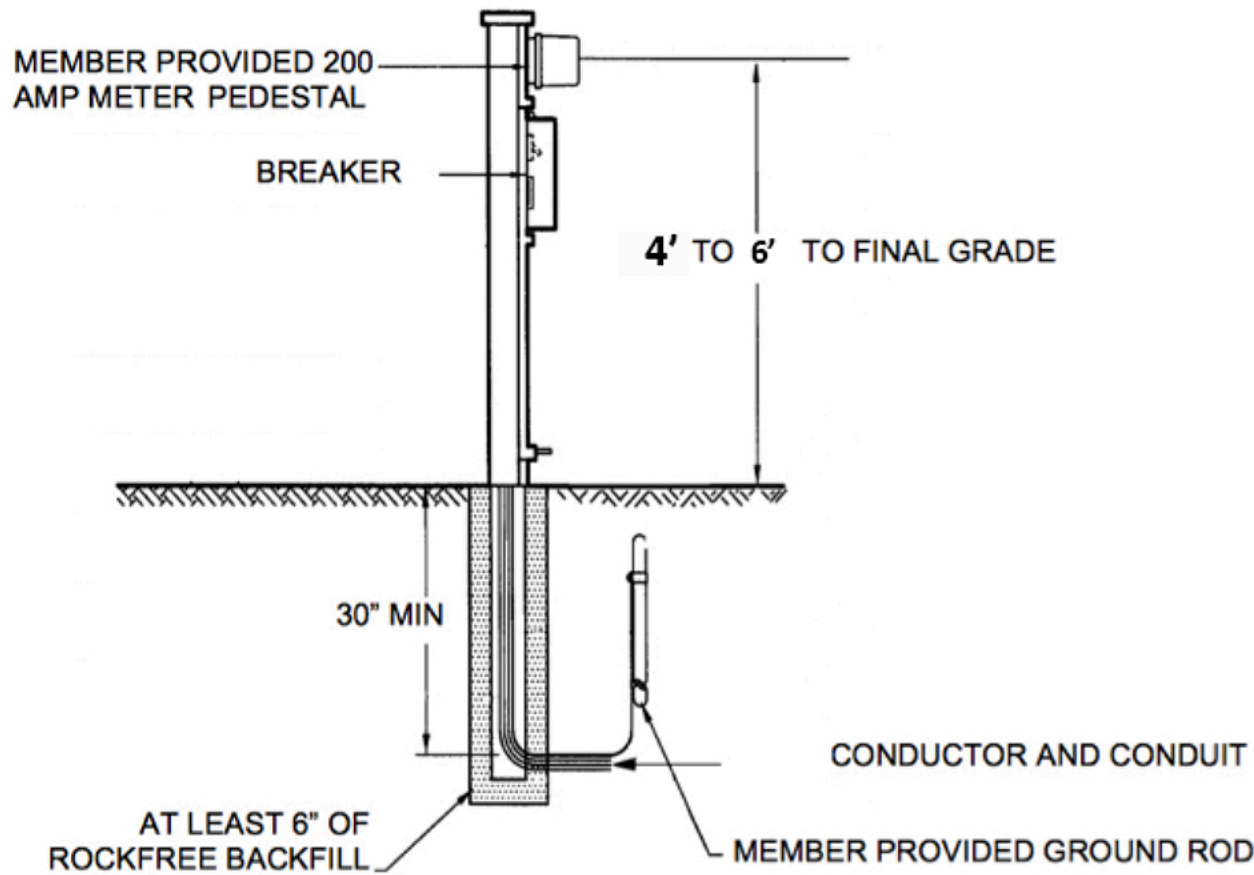

NOTES:

1. Member will provide meter base/pedestal. **200 amp (400-amp breaker) is required at meter pedestal on all installations. Manual lever bypass with disconnect is required on 400 amp or commercial self-contained meter accounts.**
2. Meter height **4'** to **6'** from center of meter.
3. Member will provide 3" riser from the bottom of meter Base to 18" below final grade and slip joint above ground and sweep 90 degrees, 30" min
4. Member will provide ground rod(s).
5. Sleeve to be provided at proper depth if driveway is poured prior to service installation.
6. Trenching will be provided by the member and to Garkane specifications.
7. At least 4' separation between power and gas and/or water.
8. **Inspector having jurisdiction must inspect meter base before service will be energized by Garkane.**

TEMPORARY METER PEDESTAL

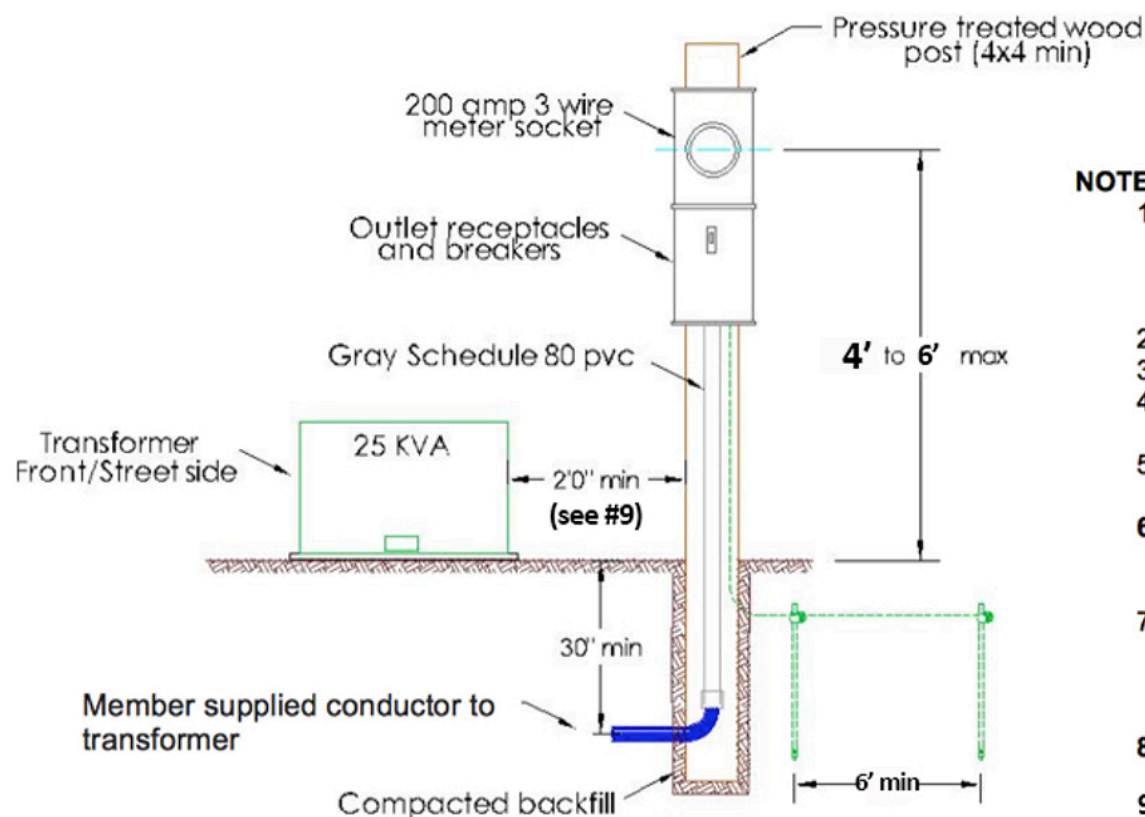

NOTES:

1. Member will provide the whole temporary meter pedestal (post, meter socket, breakers, conduit, outlets, and enough wire to reach from temporary to the inside of the transformer).
2. Meter height **4'** to **6'** from center of meter.
3. Member will provide ground rod(s).
4. Trenching will be provided by the member and to Garkane specifications.
5. At least 4' separation between power and gas/water.
6. **Inspector with jurisdiction must inspect temporary meter pedestal before service will be energized by Garkane**
7. Temporary meter pedestal will be set no less than 2' from transformer and no more than 10' unless pre-approved by a Garkane System Designer, Line Crew Foreman, or Serviceman.
8. **200 Amp (or 400 amp) breaker is required at meter pedestal on all installations.**
9. 2' minimum between transformer and meter base and if less than 6', transformer and meter electrical grounds must be electrically interconnected.

UNDERGROUND SERVICE INSTALLATIONS

Trenching Specifications (Primary and Secondary)

- All service locations that receive a significant amount of snow will be installed using underground methods.
- Conduit or secondary underground service conductor will not be installed to member's facility until an inspected meter base is in place. All conduit and conductor will be installed by Garkane.
- Member will provide a clean, rock-free trench with a 6" bedding of rock-free dirt or sand above and below the conductor and conduit. Trench must be straight from point to point as shown on the staking sheet. Trench bottom shall be level and smooth with no foreign material, rocks or sharp edges. 6" minimum clean bedding and backfill with no solid material over 1" diameter, no foreign material is permitted. Complete trench must be backfilled. All backfill shall be firmly stamped into place prior to energized cable. Customer is responsible for all backfill settlement issues.
- Primary trenches will be 48" deep with a 6" bedding of rock-free dirt or sand and 18" wide. The conductor will be 42" below final grade. (Exception: Solid rock trenches will be accepted at 42" with 6" bedding above & below with 1" minus material. So, the conductor will be buried 36" below final grade.
- Secondary trenches will be 36" deep with a 6" bedding of rock-free dirt or sand and 18" wide. The conductor will be 30" below final grade.
- A Garkane employee will require an inspection after bedding, before and after backfilling.
- Depths specified are to finished grade.
- It is the responsibility of the member to make sure the trenches are in the allotted easements.
- Garkane employees will not enter trenches that do not meet OSHA's excavation standards, 29 CFR 1926.651. (Spoils must be a minimum of 2 feet back from the trench).
- When gas or water lines cross in the trench with electric lines, there must be at least one foot of vertical separation.
- Conductor will not be energized until backfill is properly completed.
- Garkane will supply marking tape to be placed 12" above conductor.
- Road Crossing: All road crossing requires a minimum 4" conduit installed under roadway at proper depth (extending pass the edge of the road).

Primary Trench

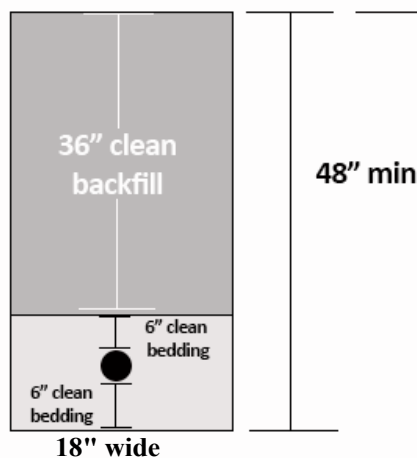

Secondary Trench

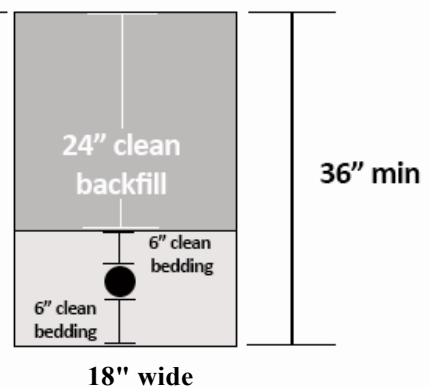

Joint Use Trench: Members and developers requiring a joint use trench where telephone and television cable are within the electric trench are solely responsible for all coordination between the included utilities. All utilities requesting joint-use trenches must be designed and ready to be installed at the time the Garkane facilities are scheduled for construction. A minimum 1-foot separation is required between electrical and all other services that share the trench. Although utilities such as phone and television cables are allowed in Garkane trenches, for the safety of personnel, Garkane does not allow

customer-owned installations such as control cables, wiring or 120/240 V secondary service wires. Any customer whose trench does not meet the above specifications and causes the Line Crew or Serviceman an extra trip will be subject to an additional fee.

OVERHEAD SERVICE INSTALLATIONS

Permanent Service - Mast on building

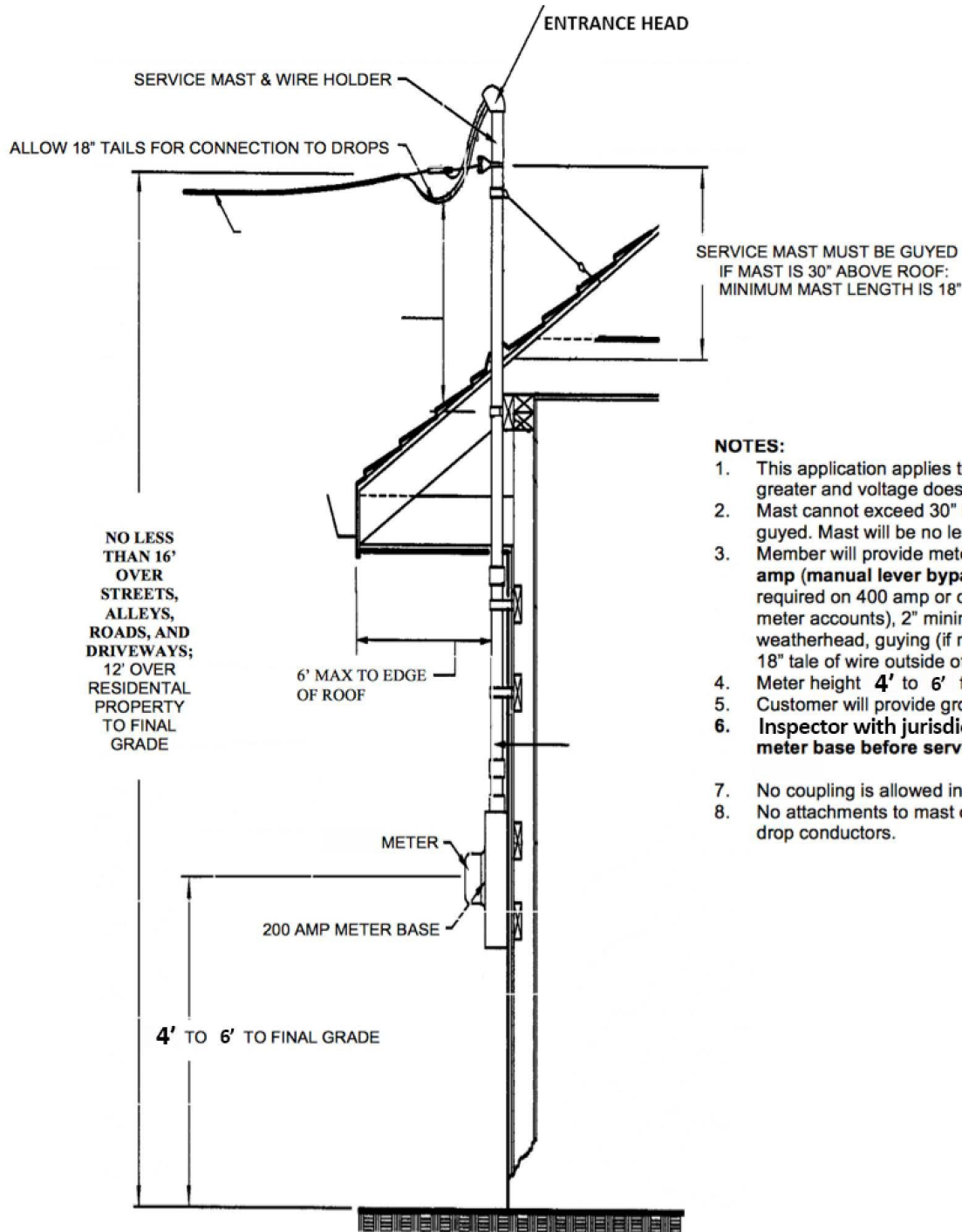

NOTES:

1. This application applies to a slope of 4" in 12" or greater and voltage does not exceed 300 volts.
2. Mast cannot exceed 30' in height without being guyed. Mast will be no less than 18".
3. Member will provide meter base - **200 amp or 400-amp (manual lever bypass with disconnect required on 400 amp or commercial self-contained meter accounts), 2" minimum GRC conduit, mast, weatherhead, guying (if needed) and at least an 18" tale of wire outside of the weatherhead.**
4. Meter height **4' to 6'** from center of meter.
5. Customer will provide ground rod(s).
6. **Inspector with jurisdiction must inspect meter base before service will be energized by**
7. No coupling is allowed in the top 10' of the mast.
8. No attachments to mast other than power service drop conductors.

DEVELOPER POLICY

Definition of a Developer

A person or an entity who develops a piece of property into more than two lots, duly approved by the governing body of the city, county, or state; with the intent being the sale of said lots for profit.

Responsibilities of the Developer

The developer shall, in advance, provide to Garkane an accurate plat of the subdivision tract duly approved by and filed with the county, city or any other entity having jurisdiction, showing the location of lots, streets, alleys, existing buildings, existing utilities, and any other underground installations or obstructions. The Developer will provide and identify permanent right-of-way easements that are compatible with Garkane's policies for design, installation, operation, and maintenance of the system including the necessary access to and from the development. **Garkane requires front lot line easements for underground electric facilities.** The Developer will provide Garkane with all pertinent load data to be used in design. **It is also the responsibility of the developer to make sure the trenches for the primary wire are in the easements. The Developer will provide permanent final grade and property corner pins prior to the installation of underground facilities.**

Process for submitting electronic plats for developments and subdivisions

The Garkane System Design Department and Geographic Information Systems require all developers to submit to Garkane the latest and most updated (preliminary) electronic version of their development **before a Garkane System Designer can meet with persons involved in planning the backbone for that development.** This information will be used to post the development to Garkane's mapping system and for use in laying out the electric backbone for that development.

There are several ways a developer can get the requested electronic plat to Garkane. All versions of the plat should be in an AutoCAD (.dwg) format. The document can be burned to a compact disc and submitted to Garkane at the time the developer signs up for service. The developer can also upload the document on a USB memory stick (jump or thumb drive) and bring it to Garkane to download the information. Or, the developer can post the plat to Garkane's file transfer protocol site. The address for this site is:

Please inform Garkane in the manner listed above if anything in the development changes.

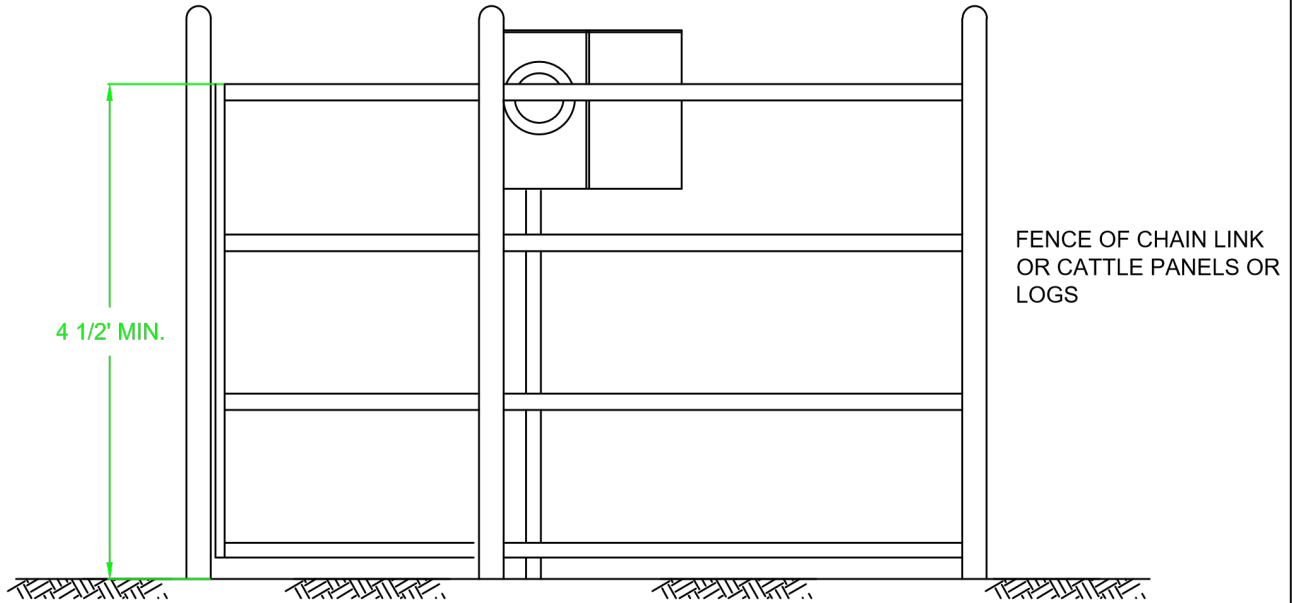
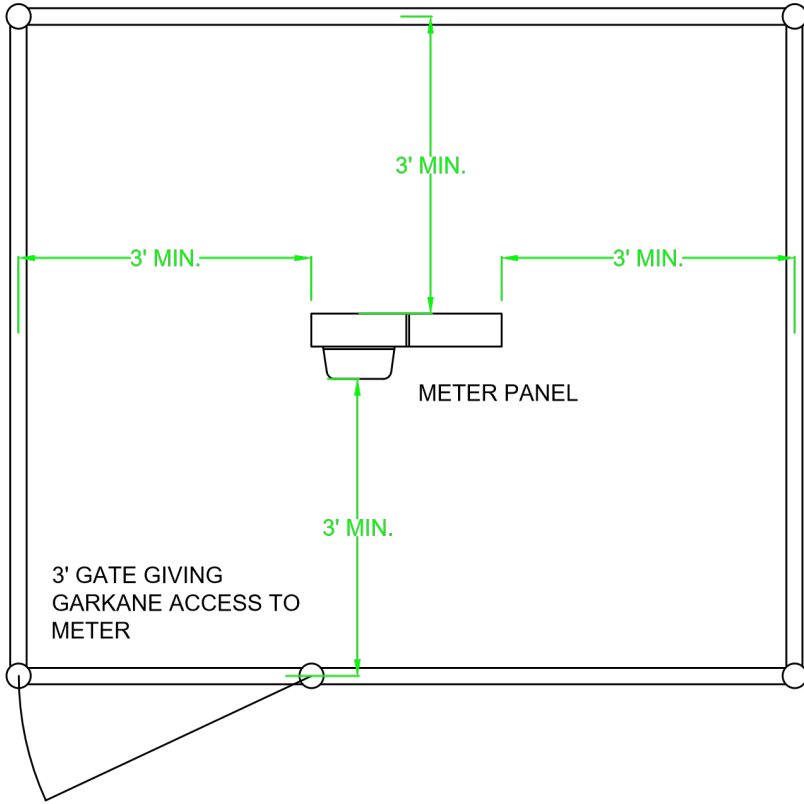

METER BASE PROTECTION FROM LIVESTOCK

1	LWC	07/08/20
NO.	REVISION	DATE



1Ø 120/240V 100 & 200 AMP
RESIDENTIAL

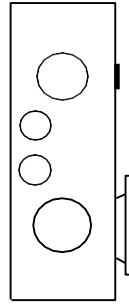
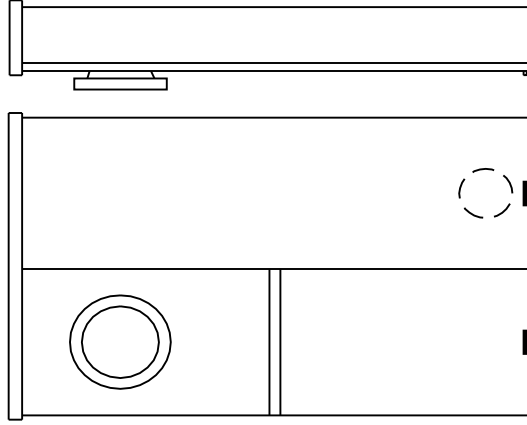

4 TERMINAL, 200 AMP
MILBANK CAT #
U3584,
OR EQUAL

GRADE



DATE		
REVISION	TYPICAL RESIDENTIAL 100 & 200 AMP METER BASE	
	FILE NAME: 01 Meter Base Dwg	SHEET: 1 OF 1
	DRAWN BY: LWC	CHECKED BY: M. AVANT
		DATE: 06-21-16

1Ø 120/240V 100 & 200 AMP
LOAD CENTER PEDESTAL - RESIDENTIAL

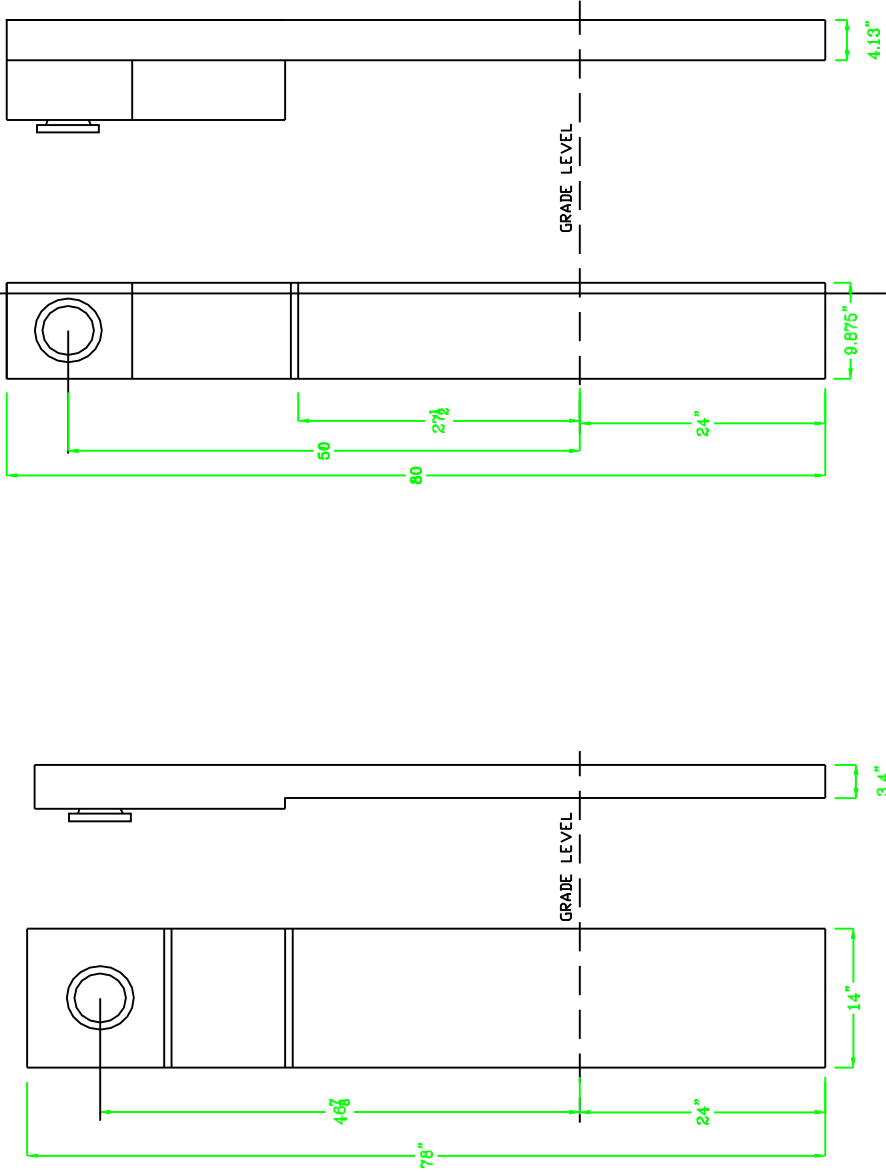

4 TERMINAL, 200 AMP
MILBANK CAT #
U5925-D-200
DR EQUAL

4 TERMINAL, 200 AMP
MILBANK CAT #
U6220-D-200-10GR
DR EQUAL

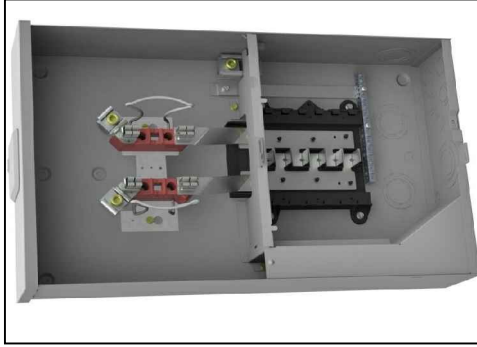

	
METER MAIN - RESIDENTIAL W/ LOAD CENTER PEDESTAL	
FILE NAME: 02 Milbank PG 54	MILBANK REC PG 54
DRAWN BY: LWC	CHECKED BY: M. AVANT
DATE:	DATE: 07-26-16
SHEET: 1 OF 1	DATE: 07-26-16

Link bypass meterbase are no longer accepted.

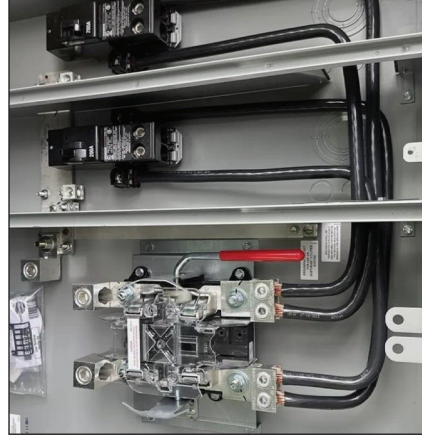
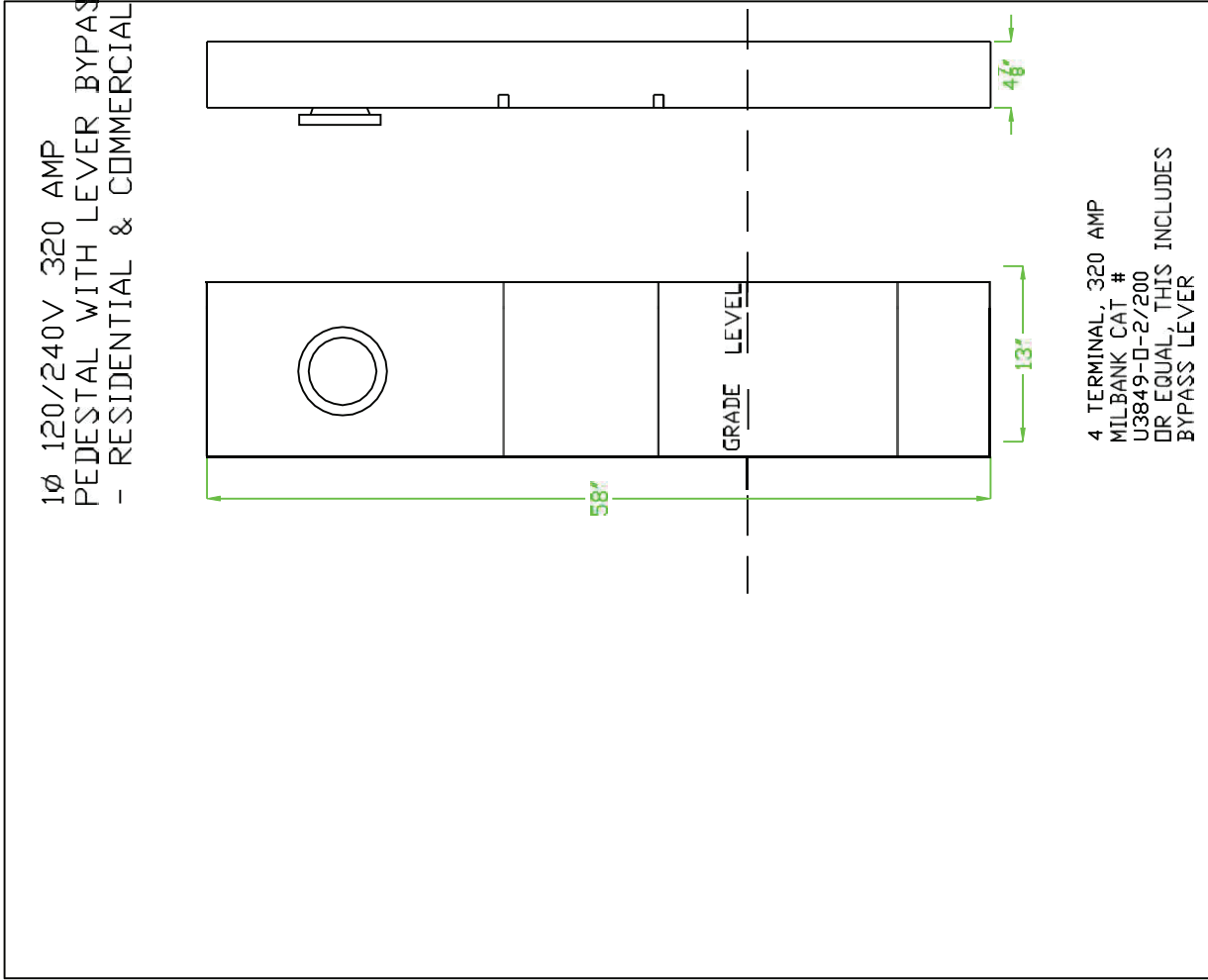

DATE			RESIDENTIAL & COMMERCIAL 320 AMP LEVER BYPASS PEDESTAL	MILBANK REC PG 59	
REVISION				FILE NAME: 04_Milbank PG 55	SHEET 1 OF 1
				DRAWN BY: LWC	CHECKED BY: M. AVANT

Lever bypass are required for all residential services over 200 amp and ALL commercial services.

1Ø 120/240V 320 AMP
 PEDESTAL WITH LEVER BYPASS
 - RESIDENTIAL & COMMERCIAL

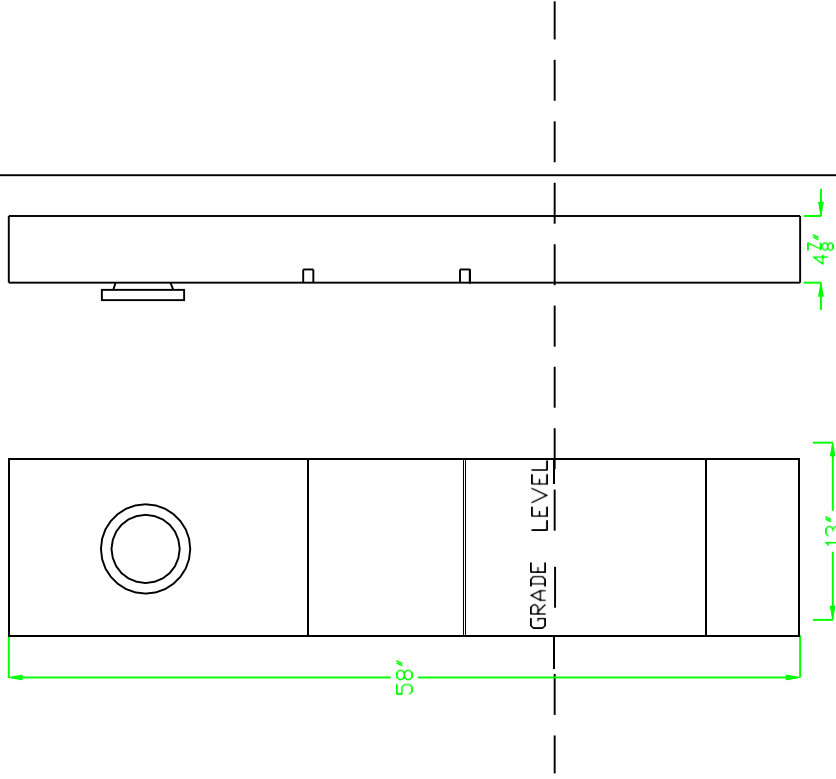

4 TERMINAL, 320 AMP
 MILBANK CAT #
 U3849-D-2/200
 OR EQUAL, THIS INCLUDES
 BYPASS LEVER



REVISION	DATE

Garkane <i>energy</i>	
RESIDENTIAL & COMMERCIAL 320 AMP LEVER BYPASS PEDESTAL	
MILBANK REC PG 59	DATE: 07-28-16
FILE NAME: D:\MILBANK PG 59 SHEET 1.DWG	CHECKED BY: M. AVANT
DRAWN BY: LWC	

STAND ALONE METER PEDESTALS SHALL BE MOUNTED ON MINIMUM 2" IMC CONDUIT CEMENTED IN

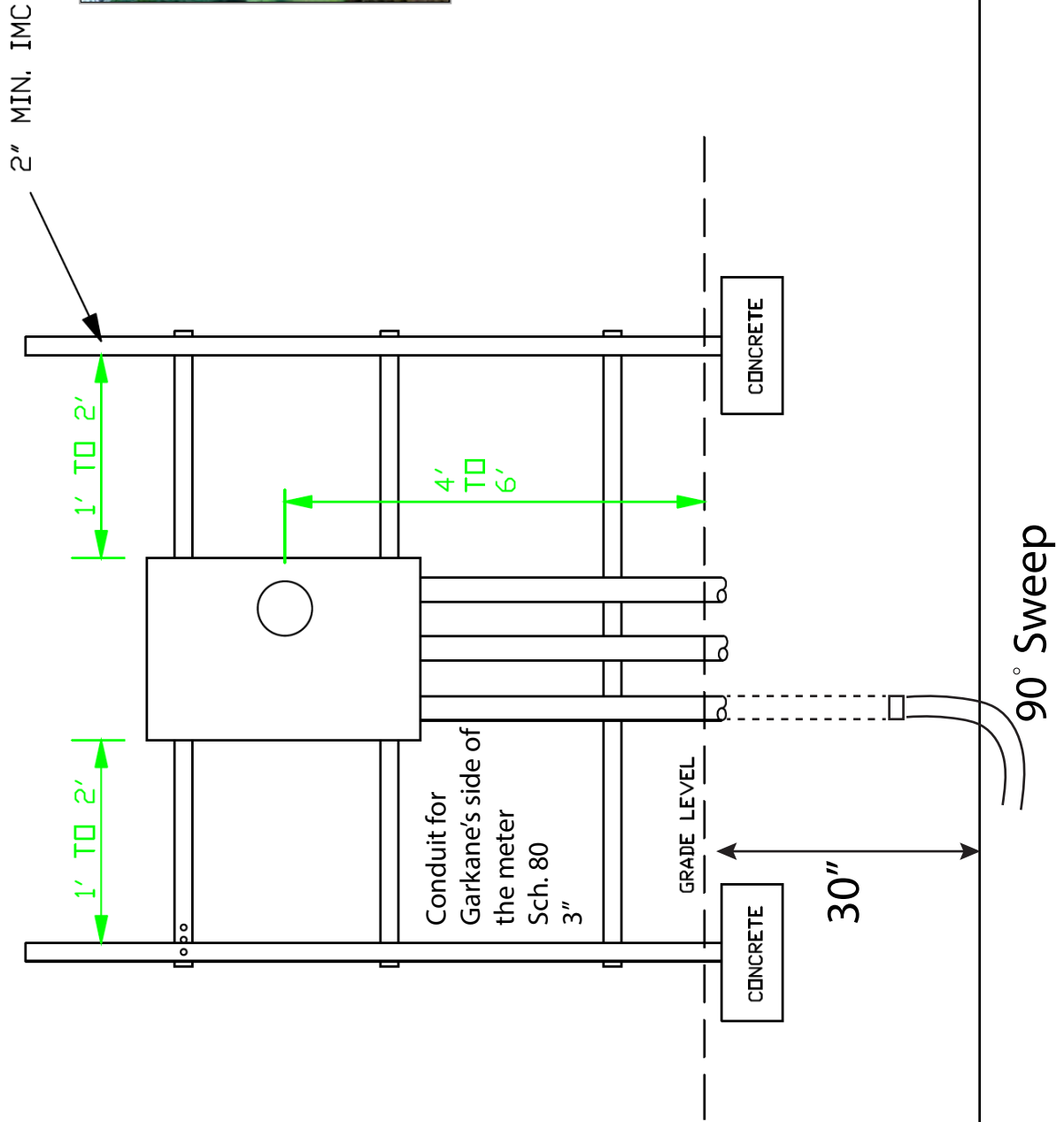

		RESIDENTIAL & COMMERCIAL STAND ALONE METER PEDESTAL	<small>FILE NAME: 05 STAND ALONE SHEET 1 OF 1 DATE: 09-21-17 DRAWN BY: LWC CHECKED BY: M. AVANT</small>

1Ø 240/480V 200 AMP AND UNDER

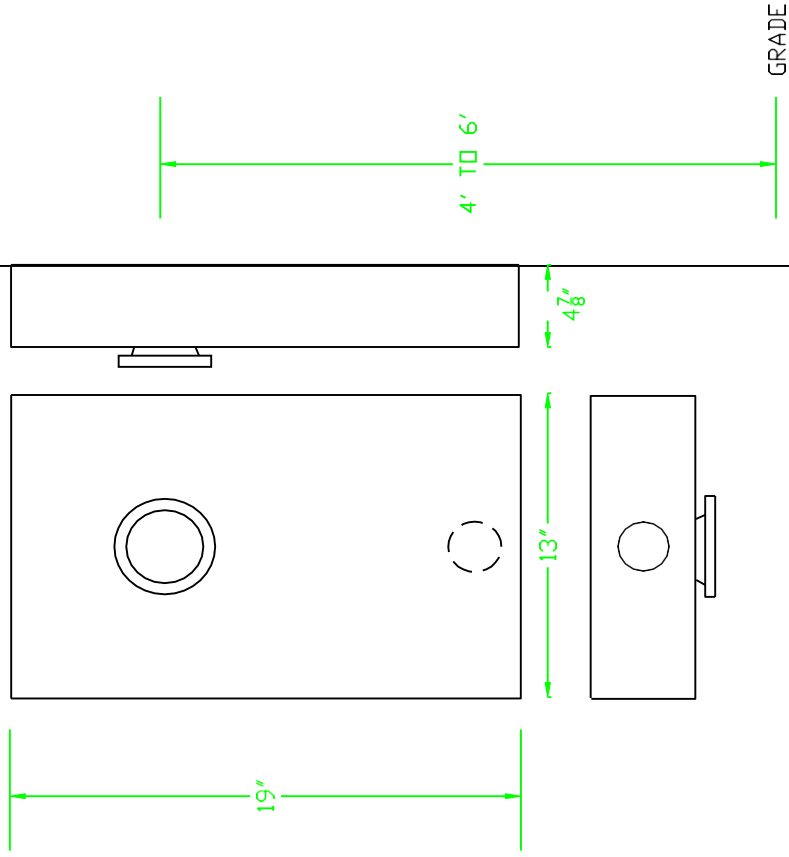

5 TERMINAL, 200 AMP AND UNDER
 MILBANK CAT #
 U9551-X-0G-HSP 5 JAW DR EQUAL.
 INCLUDES LEVER BYPASS.
 or Talon Meter 40405-02CD
 + Main Disconnect



DATE			TYPICAL 1Ø 240/480V 200 AMP AND UNDER W/ LEVER BYPASS
REVISION			
		MILBANK PG 12	DATE 05-21-16
		FILE NAME: 05 Meter Base Dwg. SHEET 1 OF 1	CHECKED BY: M. AVANT
		DRAWN BY: LWC	

1Ø 120/240V 100 & 200 AMP
COMMERCIAL

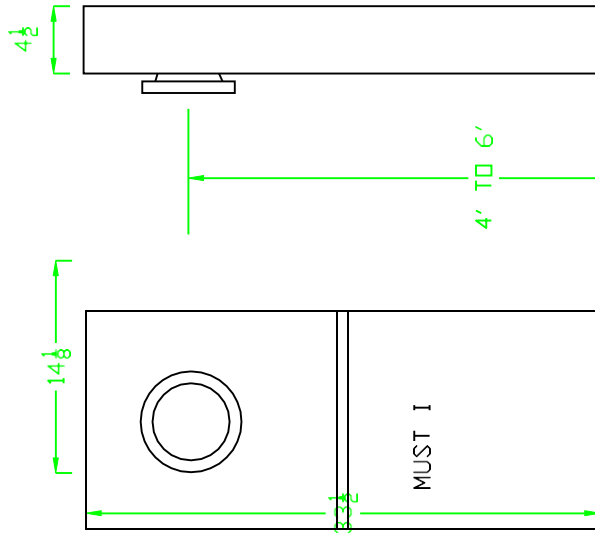

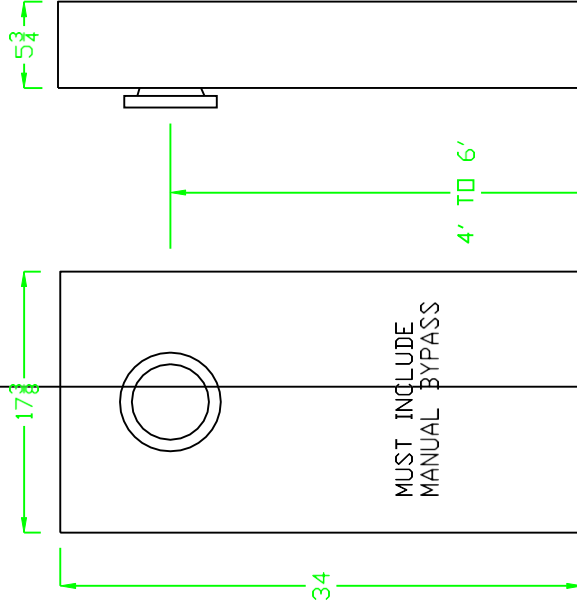

4 TERMINAL, 200 AMP
MILBANK CAT #
U5880-RXL-200-BL
OR EQUAL. THIS INCLUDES
BYPASS LEVER.
U5140-RXL-200-BL

3Ø 120/208V 200 AMP AND UNDER
3Ø 277/480V 200 AMP AND UNDER
COMMERCIAL

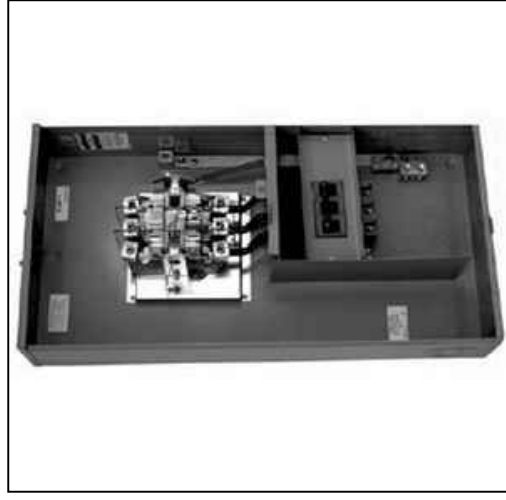

7 TERMINAL, 200 AMP
MILBANK CAT #
U5750-RXL-200-BL
OR EQUAL. THIS INCLUDES
BYPASS LEVER.



DATE		
REVISION		
TYPICAL COMMERCIAL 100 & 200 AMP METER MAINS		
MILBANK REC. PG. 23		DATE: 07-26-16
FILE NAME: 07_Milbank_PG_23	SHEET: 1 OF 1	CHECKED BY: M. AVANT
DRAWN BY: LWC		

1 ϕ 120/240V 320 AMP
W/ 2-200 AMP BREAKERS

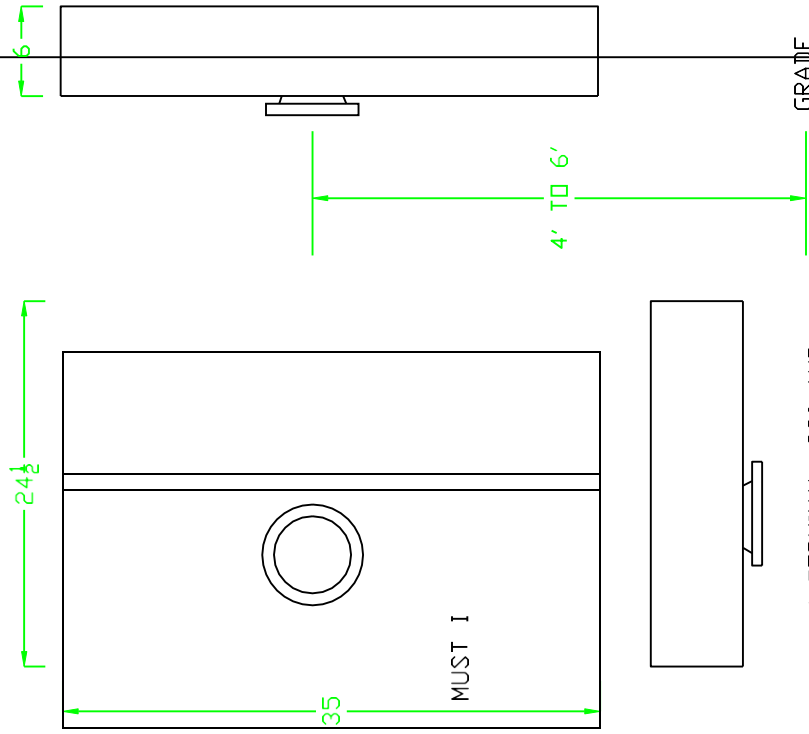

4 TERMINAL, 320 AMP,
W/ 2-200 AMP BREAKERS
MILBANK CAT #
U5890-X-2/200
OR EQUAL. THIS INCLUDES
BYPASS LEVER.



Garkane <i>energy</i>		MILBANK REC PG 24	
TYPICAL 320 AMP METER MAIN W/ 2-200 AMP BREAKERS		SHEET 1 OF 1	
DATE	FILE NAME: DB Milbank Pg 24	DRAWN BY: LWC	CHECKED BY: M. AVANT
REVISION	MILBANK REC PG 24	DATE 07-26-16	

1Ø 120/240V 320 AMP
W/ 400 AMP BREAKER

36½

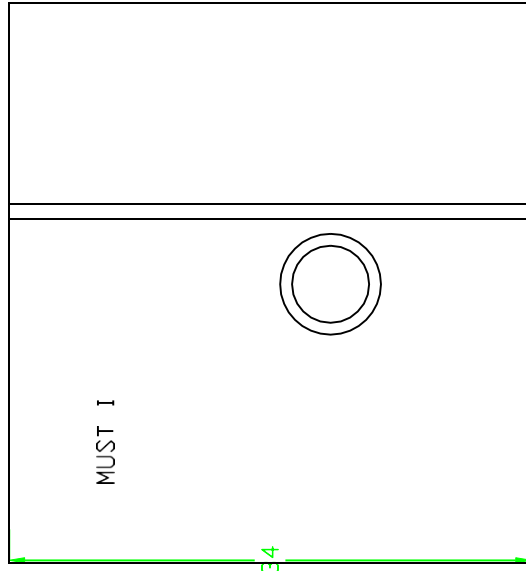

34

6

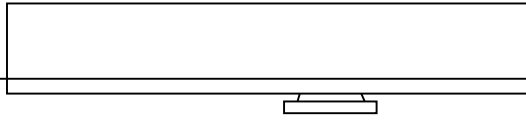

4' TO 6'

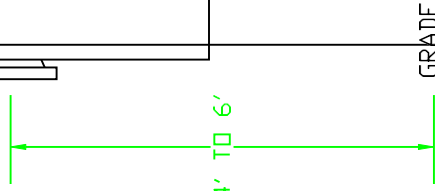

4 TERMINAL, 320 AMP
W/ 400 AMP BREAKERS
MILBANK CAT #
U6227-X-400-K3L
OR EQUAL. THIS INCLUDES
BYPASS LEVER.



Garkane <i>energy</i>		MILBANK REC PG 25	
TYPICAL 320 AMP METER MAIN W/ 400 AMP BREAKER		FILE NAME: 09 Milbank PG 25	SHEET 1 OF 1
DATE		DATE 07-28-16	
REVISION		DRAWN BY: LWC	
		CHECKED BY: M. AVANT	

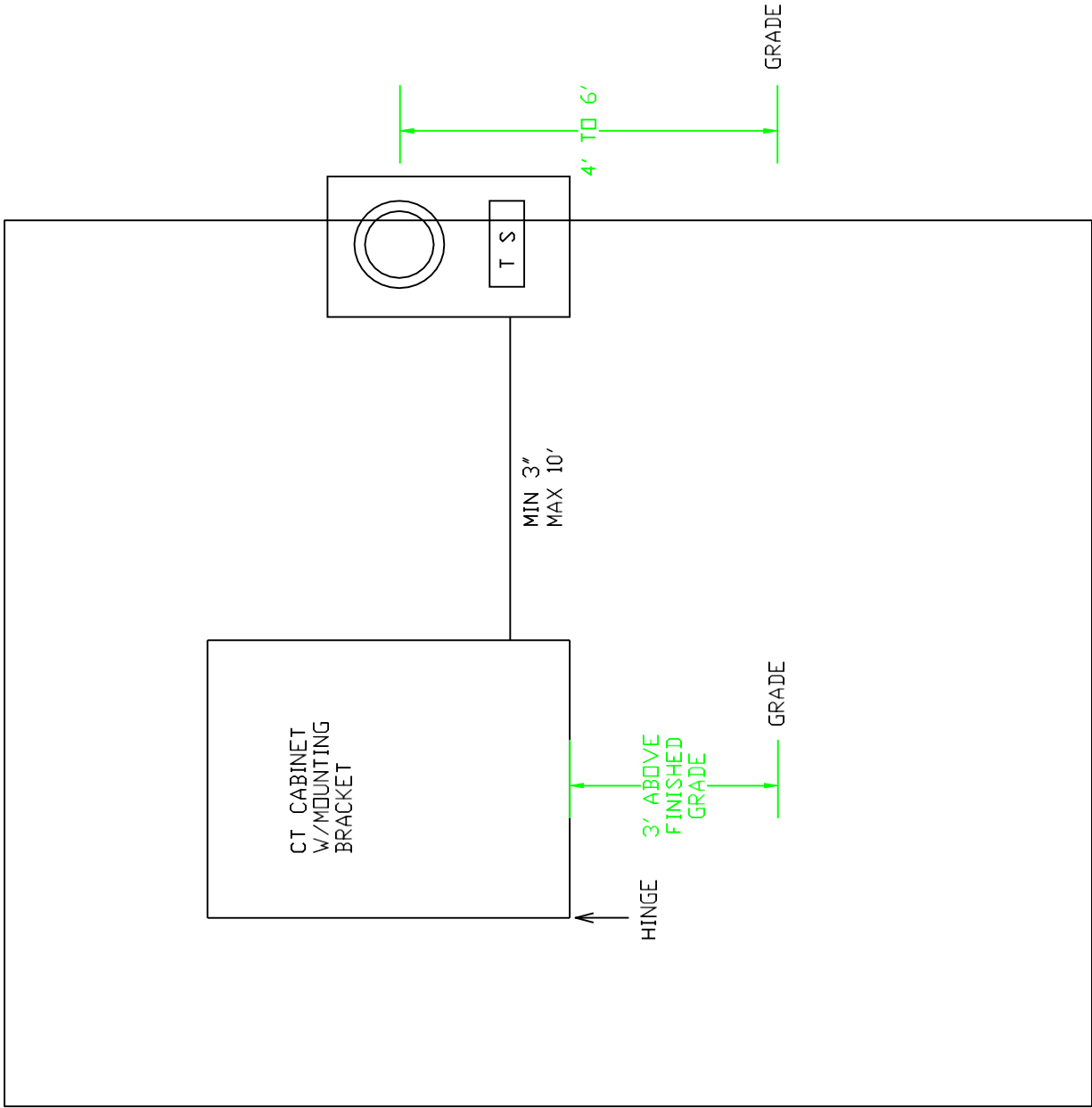

		TYPICAL CT CABINET	
		FILE NAME: 10 Typical CT Cab	SHEET: 1 OF 1
DATE	REVISION	DRAWN BY: LWC	CHECKED BY: M. AVANT

CT 1Ø 120/240V 400-800 AMP
 CT 3Ø 120/208V & 277/480V 400-800 AMP

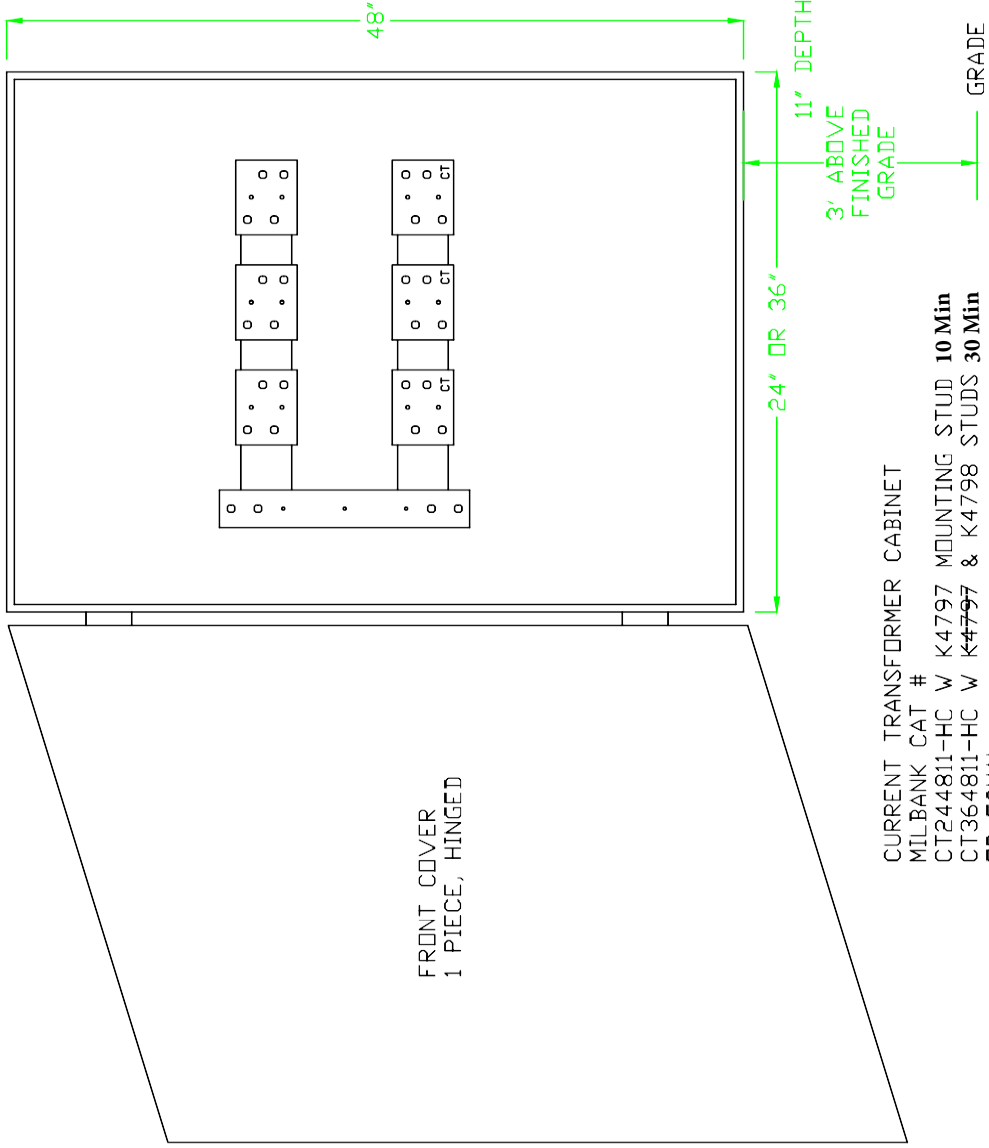

FRONT COVER
 1 PIECE, HINGED

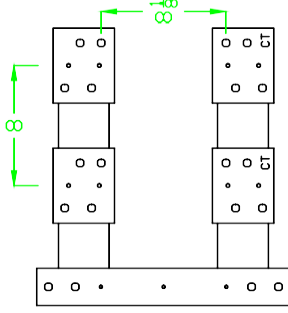

K4797 MOUNTING STUDS
 1Ø3W OR 3Ø3W

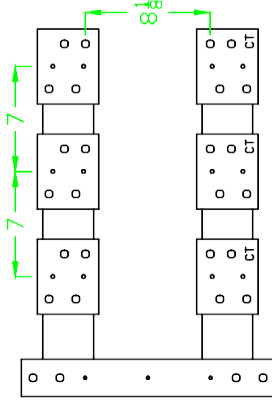

K4798 MOUNTING STUDS
 3Ø4W

SEE EUSERC DWGS 328A & 329A
 FOR DETAILS (AVAILABLE FOR REF.)

CURRENT TRANSFORMER CABINET
 MILBANK CAT # K4797 MOUNTING STUD 10 Min
 CT244811-HC W K4797 & K4798 STUDS 30 Min
 OR EQUAL

		CURRENT TRANSFORMER CABINETS	
		400-800 AMP	
FILE NAME: 11_milbank_p3_45	SHEET: 1 OF 1	DATE: 07-26-18	
DRAWN BY: LWC	CHECKED BY: M. AVANT		

BASIC DRAWING FOR SWITCHGEAR
 1φ & 3φ

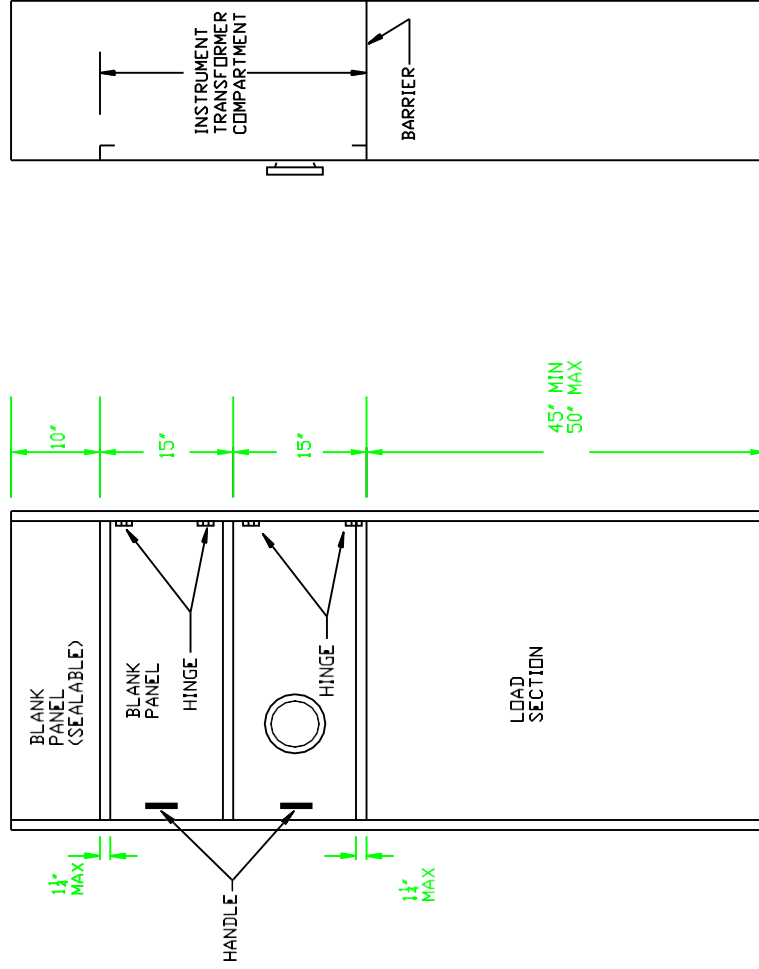

FRONT VIEW

SIDE VIEW

- MINIMUM SWITCH GEAR PROVISIONS
- CT MOUNTING SPECS
- VT MOUNTING SPECS
- FUSE PROVISIONS
- METER & TEST SWITCH PROVISIONS

	
BASIC SWITCHGEAR 1φ & 3φ	
EUSERC DWG #325	
FILE NAME: 12 Switch Gear	SHEET 1 OF 1
DATE: 05-21-16	CHECKED BY: M. AVANT
DRAWN BY: LWC	DATE:
REVISION	DATE